

3M Carbon Monoxide Sensor 529-05-22

User Instructions

For use with 3M™ Carbon Monoxide Monitor

GENERAL SAFETY INFORMATION

Intended Use

Replacement of electrochemical sensor in 3M™ Carbon Monoxide Monitor.

USE INSTRUCTIONS AND LIMITATIONS

Important

Before use, the wearer must read and understand these *User Instructions*. Keep these instructions for reference.

⚠ WARNING

Use of equipment described in these *User Instructions* must be in accordance with applicable health and safety standards or pursuant to the recommendations of an industrial hygienist. Do not use with parts or accessories other than those supplied by 3M as specified in these *User Instructions*. Failure to do so can reduce respirator effectiveness and **result in sickness or death.**

REPLACEMENT INSTALLATION INSTRUCTIONS

1. Remove the 2 knurled thumbscrews at monitor bottom. Pull the bottom plate off the housing as far as wiring will allow.
2. If wires are connected to tab, pin or round circuit board connectors, see Installation Instructions A, (Fig. 1).
3. If wires are connected to a rectangular circuit board that is attached to the flow block by screws, see Installation Instructions B, (Fig. 2).
4. Remove carbon monoxide (CO) sensor from its cavity in the flow block on top of bottom plate. Pull tab, pin or round circuit board wire connectors off tab/pins of sensor, noting the color-coding. If rectangular screw-mounted circuit board is supplied, unscrew the 2 mounting screws and remove sensor from flow block cavity. Pull circuit board connectors off pins of sensor.
5. Discard old CO sensor. It contains a small amount of sulfuric acid. Dispose of sensor according to local regulations.

⚠ WARNING

Sulfuric acid is poisonous and can cause severe burns. Do not allow acid to contact skin or eyes. If eyes are exposed to acid, flush thoroughly and seek immediate medical attention.

CAUTION: Always wash hands thoroughly after handling CO sensor.

Installation Instructions A

If you have the old tab wire harness, please contact 3M Warranty and Repair Center in U.S.A. at 1-800-243-4630, option 3, for the new pin wire harness. In Canada, call 3M at 1-800-267-4414. **DO NOT SOLDER** wires of old tab wire harness to sensors' pins; damage to sensor will occur.

1. To install new pin wire harness, remove the 6 screws holding the monitor's faceplate to housing.
2. Locate the old wire harness white 5-point connector plugged into the main circuit board mounted on faceplate. Remove the old connector and plug in its place the new white 5-point connector of new wire harness. Re-install monitor's faceplate to housing and discard old tab wire harness.
3. Attach the pin or circuit board wire harness to new sensor as listed below.

WIRE COLOR	SENSOR PIN TERMINAL
Black	CNTR
Blue	REF
Red	SENSING

4. The fourth pin on sensor is used only as a guide pin to install circuit board to sensor, if supplied. New sensors come with a shorting wire/spring connecting the sensing and reference pins. Remove and discard before attaching wire harness connectors.
5. Be sure flow block cavity is clean and dry and a small amount of petroleum jelly or similar lubricant is applied on the o-ring seal within block. Then push the CO sensor into block with a twisting motion until it seats on the ledge halfway down.
6. Replace the bottom plate and secure it with thumbscrews. Make sure the inlet swivel elbow and hose barb fitting are firmly tightened.
7. Power monitor and allow at least one hour stabilization and then calibrate monitor.

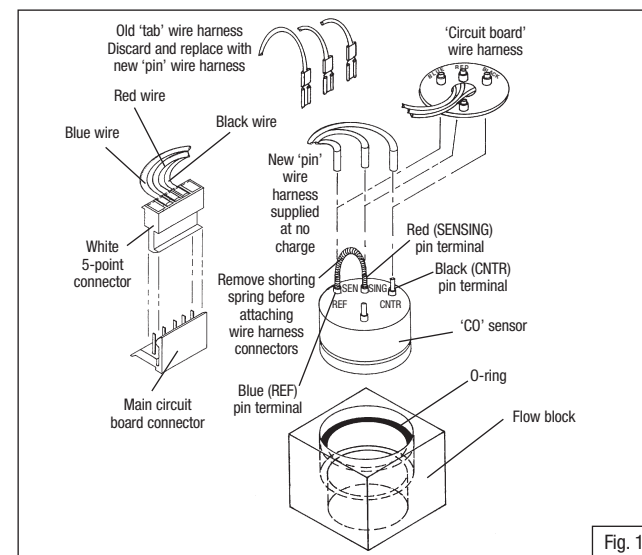

Fig. 1

Installation Instructions B

1. After old sensor has been removed and disposed of, note o-ring located at bottom of flow block. **DO NOT LOSE.**
2. The wire connectors' circuit board relates to the sensors' 3 pins as shown below.

WIRE COLOR

Black
Blue
Red

SENSOR PIN TERMINAL

CNTR
REF
SENSING

3. The fourth pin on sensor is used as a guide pin to install circuit board to sensor.
4. Carefully press circuit board on sensors' 4 pins evenly. New sensors come with a shorting wire/spring between sensing and reference pins. Remove and discard before pressing circuit board connectors in place.
5. Be sure flow block cavity and o-ring are dry and clean of oils, etc. The o-ring must be positioned evenly in bottom of flow block cavity.
6. Push the sensor in block against o-ring and evenly tighten the 2 screws that hold circuit board/sensor to flow block. Tighten screws lightly to assure good seal with o-ring.
7. Do not overtighten screws, or damage to circuit board/sensor may occur.
8. Replace the bottom plate and secure it with thumbscrews. Make sure the inlet sample swivel elbow and hose barb fitting is firmly tightened.
9. Power monitor and allow at least one hour stabilization and then calibrate monitor.

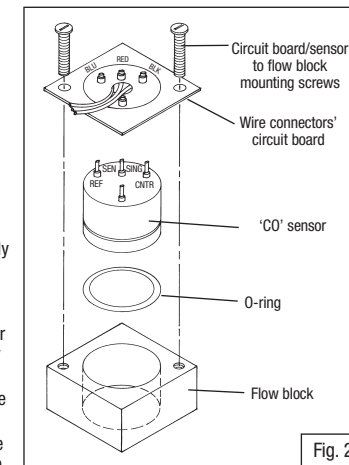

Fig. 2

FOR MORE INFORMATION

In United States, contact:

Internet: www.3m.com/occsafety
Technical Assistance 1-800-243-4630

For other 3M products:

1-800-3M-HELPS or 1-651-737-6501

In Canada, contact:

Internet: www.3m.com/CA/occsafety
Technical Assistance: 1 800 267-4414

For other 3M products:

1 800 364-3577



⚠ WARNING

3M's respirator products help provide protection against certain airborne hazards. **Misuse may result in sickness or death.** For proper use, see supervisor, *User Instructions* or call 3M in U.S.A., 1-800-243-4630.

In Canada, call Technical Service at 1-800-267-4414.

3M Occupational Health and Environmental Safety Division

3M Center, Building 235-2W-70
P.O. Box 33010
St. Paul, MN 55133-3010

Printed in the U. S. A.

3M Occupational Health and Environmental Safety Division 3M Canada Company

P.O. Box 5757
London, Ontario N6A 4T1

Printed in the U. S. A.